

# FG 300 'Arrow' Application

Providing Positive Guidance at Toll Plazas



**Thirty FG 300 Model UR Posts create three "arrows"**

Shutoko Metropolitan Expressway  
Wangan Line, Tokyo Japan.  
Installed March 2014

→  
"Arrow" posts without  
headlight reflection

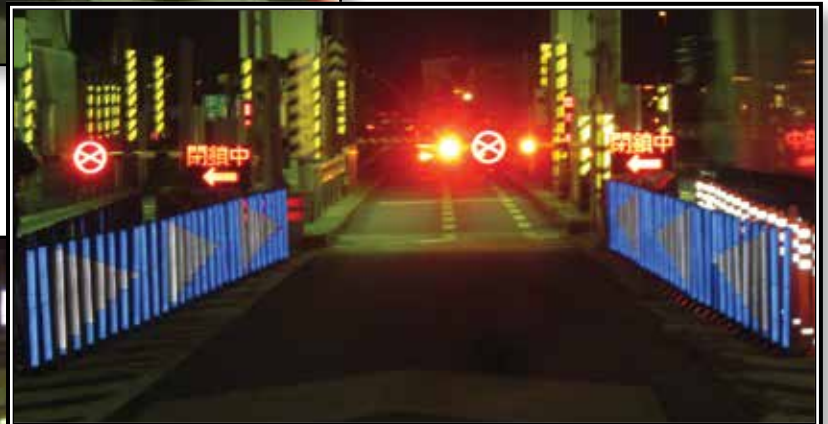

**"Arrows" can be made by applying white reflective sheeting to dark colored posts — visible day and night**



←  
"Arrow" posts with  
headlight reflection



SET OF THIRTY POSTS - LAYOUT

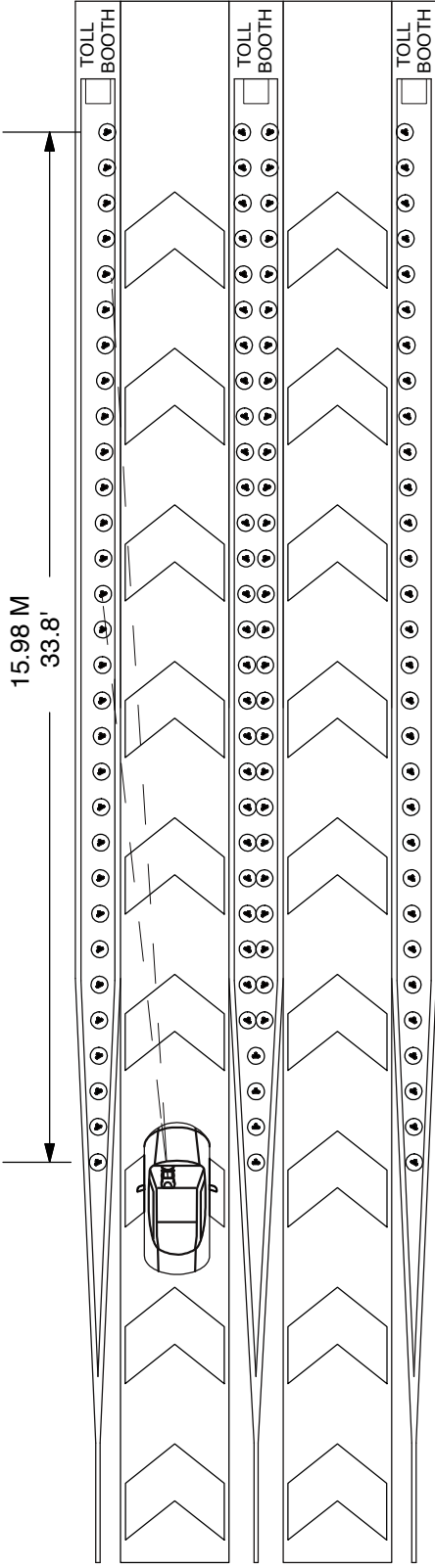

SET OF TEN POSTS - LAYOUT PATTERN

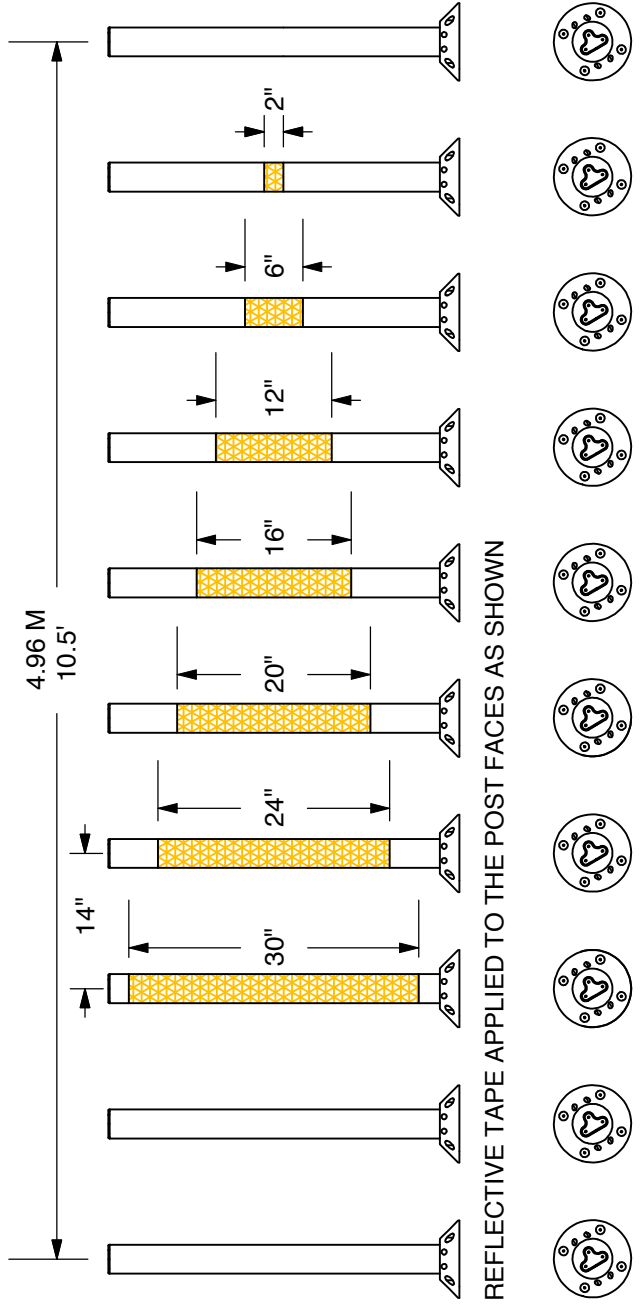

REFLECTIVE TAPE APPLIED TO THE POST FACES AS SHOWN

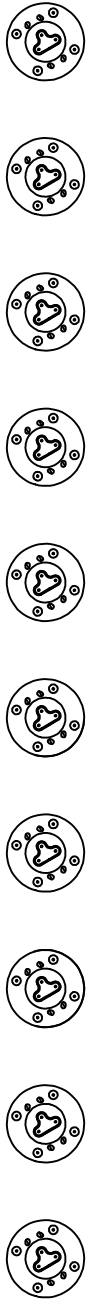

TOP VIEW - POSTS ROTATED 30 DEGREES FOR INSTALLATION

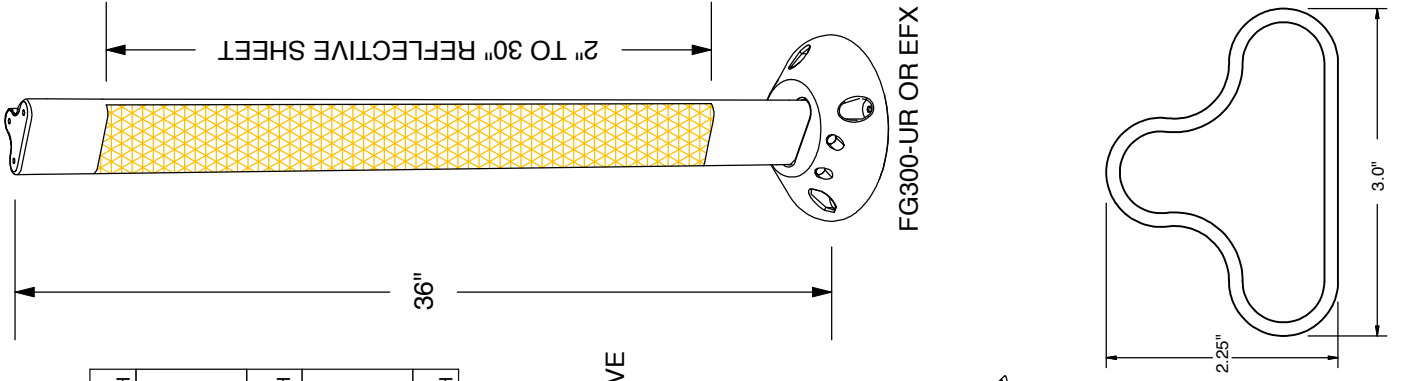

DRIVER PERSPECTIVE

