

SAFETY TOP CAP™



Safety Top Cap™ is our premium sports fencing protection product.

The unique design provides protection against bodily injury by covering the exposed knuckles or barbs on top of a chain link fence. It also increases visibility of the fence for player safety while acting as a decorative trim piece to enhance any galvanized or colored chain link fence system.

Comes conveniently cut in 8' lengths, and unlike some economy fence cap products, requires no special tools for installation.

Don't settle for competitive designs and styles that pose an installation challenge, do not blend with the natural contours on the top of the fence, nor offer our impressive, long-term warranty.

Design

The durable and flexible plastic in a large unique tubular shape, allows the Safety Top Cap to fit securely over the fence's top rail while providing an appealing flat surface on the front of the fence.

Multiple Uses

Primarily used in our safety yellow color for baseball outfields. This product is also growing in popularity at athletic fields, parks, playgrounds and recreational facilities throughout the country.

Colors*



Safety Yellow is our standard (stocking) color however Safety Top Cap™ can also be special ordered in our standard fence slat colors and Scarlet Red upon request - minimum order quantities apply.

* Exact representation of slat colors in printing is difficult. Please refer to actual color samples for final matching.



FENCE PRODUCTS

PDS® is a registered trademark of Pexco.

Made in the USA





PRODUCT SPECIFICATIONS

| Product Type | Cap Height | Cap Width | Cap Length | Contents Per Bag | Approx. Coverage Per Box | Bag Weight |
|-----------------|------------|-----------|------------|----------------------------|--------------------------|------------|
| Safety Top Cap™ | 5½" | 2¾" | 8' | 5 Top Caps 15 Hog Rings | 40 linear feet | 20 lbs |

Materials

The Safety Top Cap product is extruded from High Density Polyethylene (HDPE), color pigments and ultra violet (UV) inhibitors, specifically designed to retard the harmful effects of the sun and lengthen the life of the product.

Durability

Manufactured using Pexco PDS® HDPE plastic with UV stabilizers. This product is designed to endure high impact, to resist the harmful effects of the sun, and withstand severe weather conditions, salt water, sand, road dirt, most acids, alcohol, alkaline, ammonia, petroleum distillates, and common environmental pollutants.

Maintenance

Pressure cleaning of surface contaminants is quickly accomplished with plain water.

Security

Resist vandalism by using the hog rings to permanently attach the Safety Top Cap to the fence.

Limited Warranty

Safety Top Cap carries a 15-year, pro-rata warranty against breakage under normal conditions. Write Pexco for full warranty information.

Installation Instructions

Simply "snap" over the top of the fence and lock to the wire mesh with steel hog-rings (included with each package) through the pre-drilled holes on each piece.

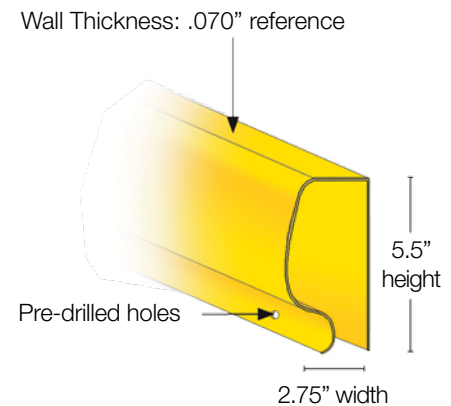

HDPE Technical Properties

| Property | Value |
|------------------|---|
| Melt Index | (.35) Optimum extrusion processing conditions for Fence Slats |
| Density | (.945) Polyethylene ranges anywhere from .914 to .960 in density |
| Minimum Temp. | (-70°) Under no stress, HDPE remains flexible at this temperature |
| Maximum Temp. | (180°) Under no stress, HDPE will not distort at this temperature |
| Tensile Strength | (3,700 psi) HDPE will not distort at lesser loads or impacts |

PEXCO LLC

Tacoma, WA 98424 | Athol, MA 01331
800.822.SLAT (7528) | 800.755.SLAT (7528)

VISIT US AT:

www.pexco.com/fence

EMAIL US AT:

fence.sales@pexco.com

Contact your local fence professional for more information about our complete line of enhancement products.

